

Midterm Two

Show all your work

Name: _____
 Number: _____
 Signature: _____
 Score: ____/38

Problem 1: Lines p and q are parallel. Find the measures of INTERIOR angles in $\triangle ABC$:

$\angle A =$ 25° , $\angle B =$ 100° , and $\angle C =$ 55° .

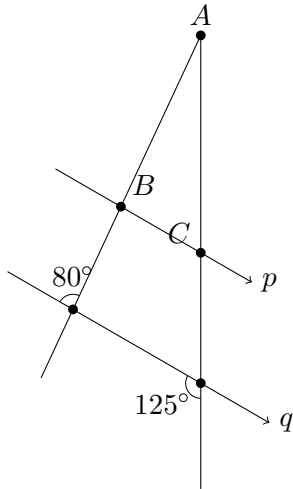

The given angle 80° is corresponding to the exterior angle at B , so the interior angle, $\angle B = 180^\circ - 80^\circ = 100^\circ$. Similarly, 125° is a corresponding angle to the exterior angle at C , so $\angle C = 180^\circ - 125^\circ = 55^\circ$ form a straight line, so they add up to 180° . The last angle, namely, $\angle A$ is found by using triangle angle sum, so $\angle A = 180^\circ - 100^\circ - 55^\circ = 25^\circ$.

Score: /3

Problem 2: Set up a table to draw all rectangles with perimeter 14 cm whose dimensions are integral in centimetre(s). Of these rectangles, which one has the largest area?

Rectangle: _____

Area: _____

If the perimeter is 14 cm, half of the perimeter is 7 cm, the sum of its length and width. Therefore, (l, w) may be $(6, 1)$, $(5, 2)$, $(4, 3)$ and its 90° rotation. The largest area is the 4×3 square of 12 cm^2 in area.

Score: /3

Problem 3: Find the PERIMETER of the quadrilateral $ACEG$ enclosed in the given rectangle $ABDF$.

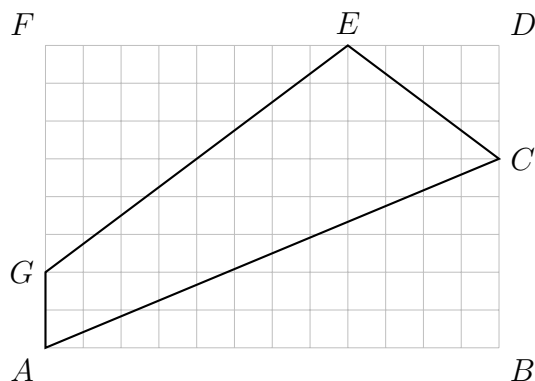

$$AC = \sqrt{5^2 + 12^2} = \sqrt{169} = 13$$

$$CE = \sqrt{3^2 + 4^2} = \sqrt{25} = 5$$

$$EG = \sqrt{6^2 + 8^2} = \sqrt{100} = 10$$

$$AG = 2$$

so the perimeter is $13 + 5 + 10 + 2 = 30$.

Score: /4

Problem 4: Euclid put two half cylinders on a square prism to make a heart prism. Find its surface area.

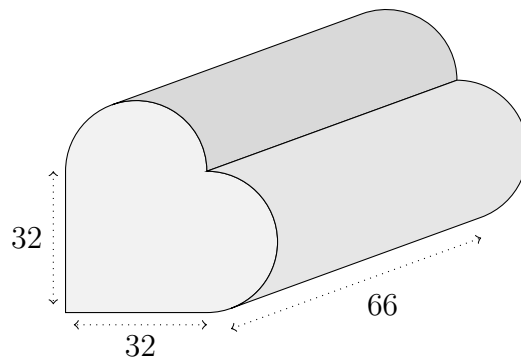

The area of the heart is $32^2 + \pi 16^2 = 1024 + 256\pi$ and its perimeter is $2 \times 32 + 2\pi 16 = 64 + 32\pi$. The surface area of the figure is therefore

$$\begin{aligned} 2(1024 + 256\pi) + 66(64 + 32\pi) &= 2048 + 512\pi + 4224 + 2112\pi \\ &= 6272 + 2624\pi \approx 14\,515.5 \text{ square units} \end{aligned}$$

Score: /3

Problem 5: Janette purchased a new pair of winter boots and paid \$224 at the cashier. Using BC's tax rate of 12%, calculate the ticket price on the boots before taxes.

If the price before taxes is \$ x , then $1.12x = \$224$, so $x = \frac{\$224}{1.12} = \200 .

Score: /3

Problem 6: How much would David's grandparents need to put in a GIC earning 3.75% to have a million dollars in 25 years? Use simple interest.

$1\,000\,000 = P(1 + 0.0375 \times 25) = 1.9375P$, so $P = 1\,000\,000/1.9375 \approx 516\,129.03$ dollars.
If you use compound interest, then $1\,000\,000 = P(1 + 0.0375)^{25} = 2.510\,167\,109P$, so $P = 398\,379.85$ dollars.

Score: /3

Problem 7: Brian's friend, Jay, graduated from university with a student loan of \$12 000 at 4% to be paid off in 3 years. Compute the monthly instalment payment.

Using simple interest, the total interest is $0.04 \times \$12\,000 \times 3 = \1440 . Jay therefore must pay a total of \$13 440, so the monthly payment is $\frac{\$13\,440}{3 \times 12} \approx \373.33 .

Using compound interest,

$$-10\,000(1 + r_p)^{36} + \frac{P}{r_p}((1 + r_p)^{36} - 1) = 0,$$

where $r_p = (1 + 0.04)^{(1/12)} - 1 \approx 0.327\,374\,0\%$, so the monthly payment is \$353.91.

Score: /3

Problem 8: If *Capilano Express* credit card charges 21.5% on unpaid balance, how much would it cost in finance charge to leave \$290 unpaid past the due date for 90 days?

$$I = Prt = 290 \times 0.215 \times \frac{90}{365} \approx 15.37 \text{ dollars.}$$

Score: /2

Problem 9: Dad constructed a spinner with four equal sectors. Draw a sample space for spinning the spinner twice. Find the probability of getting an Aero and a Mars bar (in any order) after two spins.

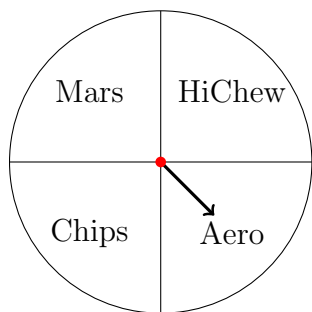

The probability of getting an Aero and a Mars Bar *in that order* is $\frac{1}{4} \times \frac{1}{4} = \frac{1}{16}$. The probability of getting a Mars Bar and an Aero in the other order is also $\frac{1}{16}$. The probability of getting a Mars Bar and an Aero in any order is therefore $\frac{1}{16} + \frac{1}{16} = \frac{1}{8}$.

Score: /3

Problem 10: Ham and Sam selected the streaming services monthly for Hamlet and Samlette depending on the shows they wanted their children to watch. The following table shows the result of a survey according to age group and the number of streaming services used on average per month. Given that a participant is selected from the 46–60 age group, what is the probability that the participant is paying for 2 streaming services?

Age	Streaming services			
	1	2	3	4+
16–30	280	435	205	78
31–45	380	129	198	54
46–60	223	552	352	452
61+	121	673	236	22

$$\frac{552}{223 + 552 + 352 + 452} = \frac{552}{1579} \approx 34.96\%$$

Score: /3

Problem 11: Samlette liked puzzles. Ham showed her a puzzle of a sample space S as a rectangle containing two events A and B . Samlette knew that $P(S) = 100\%$, $P(A) = 80\%$, and $P(B) = 60\%$, with their overlap, $P(A \cap B) = 50\%$. Help Samlette find the following probabilities through the help of a Venn diagram.

- Draw a Venn diagram prescribed by the probabilities given.
- Find $P(A \cup B)$.
- Find $P(\overline{A \cup B})$.
- Find $P(B | A)$.

- $P(A \cup B) = 0.8 + 0.6 - 0.5 = 0.9$.
- $P(\overline{A \cup B}) = 1 - P(A \cup B) = 0.1$.
- $P(B | A) = \frac{P(A \cap B)}{P(A)} = \frac{0.5}{0.80} = 0.625$.

Score: /4

Problem 12: No test is perfect. The fecal immunochemical test (FIT) is not 100% accurate, i.e. it may miss some colon cancer. Suppose 12% of those taking FIT gets abnormal results, of those, 3% has colon cancer while of those with normal FIT results, 0.1% has cancer. Starting with a FIT branching to Normal and Abnormal results first, then cancer or no cancer second, draw a probability tree for the FIT, then find the probability that given a patient without colon cancer, the patient gets a false positive for FIT.

The probability tree:

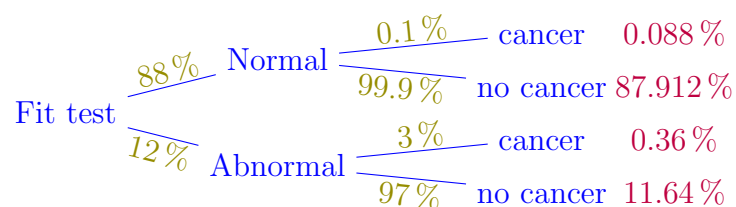

Therefore

$$P(+ | \bar{C}) = \frac{P(+ \cap \bar{C})}{P(+ \cap \bar{C}) + P(- \cap \bar{C})} = \frac{0.12 \cdot 0.97}{0.12 \cdot 0.97 + 0.88 \cdot 0.999} \approx 0.1169 = 11.69\%$$

Score: /4